

SAVE

IT'S TAX TIME

TORQUE INDUSTRIES

246 Grand Junction Road
Athol Park, SA 5012
Telephone: +618 8341 0177
Facsimile: +618 8341 1955
Email: sales@torqind.com
Website: www.torqind.com



Why not make your purchase's work for you,
in more ways than one!

At Torque Industries we can help you with all of your recycling needs,
and at the same time save you money. What could be better than that?

Take Advantage of the Australian Taxation Department's instant asset write-off!

All you need to do to qualify is be a small business with a turnover of less than \$10 million,
and you can apply to have an assets costing less than \$20,000 each instantly written-off!

Here's how we can help!

Waste Management Solutions

We offer a complete turn key solution.

From 'off the shelf' machinery to a custom build solution, the Hydra-Pac team can assist
with initial concepts and then project manage the design, building, installation
and ongoing servicing of your project.

Australia's Leading Manufacturer of Purpose Built Recycling Equipment

We can tailor the products that we have on offer to suits your individual requirements.
They are all Australian Made, with imported options available.



*"There are two aspects to waste recycling –
first, doing the right thing and
secondly, cost recovery."*



PROUD OWNERS & MANUFACTURERES OF:
HYDRA-PAC
WASTE SYSTEMS



For more information on the australian taxation office instant asset
write-off please visit: <https://www.ato.gov.au>

VERTICAL "PB" SERIES BALERS

PB28A



This machine perfect for fast food outlets, small convenience stores or where ever a baler is required in the minimum of space.

With all the features and advantages of its larger brothers, this machine will save space and money, putting an end to your waste problems.

The newly designed lock system incorporating a handwheel, allows operators to have maximum control over the door and lock, preventing kick back. Fewer mating parts means less wear and maintenance.

Specifications

Bale Size	500 x 500 x 600 H
Bale Weight	45 - 50 kg
Machine Dimensions	608 x 850 x 1962H
Loading Opening	500 x 600H
Machine Weight	350kg
Time Cycle	28 Seconds
Electrical Motor	1.1 kW - 240 Volt
Model Number	PB28A

PB40A

The PB40A is perfect for the small warehouse situation that calls for baling of tougher material.

Higher baling pressures produce good bale density, making it an economical member of your waste stream.

Our door locking system ensures total control when opening the door. This maximises safety and usability for the operator.

Forklift access to the base of the machine makes it easy for staff to move the unit for cleaning and complying with health regulations.

Specifications

Bale Size	1000 x 750 x 1150 H
Bale Weight	130 - 160 kg
Machine Dimensions	1450W x 890D x 2850H
Loading Opening	1000 x 635
Machine Weight	850kg
Time Cycle	27 Seconds
Electrical Motor	3 kW - 415 Volt
Model Number	PB40A



SALES SERVICE SOLUTIONS

SALES

[HYDRAULICS](#)
[PNEUMATICS](#)
[AIR COMPRESSORS & GAS GENERATORS](#)
[FILTRATION PRODUCTS](#)
[HOSES & FITTINGS](#)
[VACUUM EQUIPMENT](#)
[MATERIAL HANDLING](#)



SERVICE

[SERVICE DIVISON](#)
[24/7 EMERGENCY BREAKDOWN SERVICE](#)
[REPAIR CENTRE](#)
[PROGRAM MAINTENANCE](#)



SOLUTIONS

HYDRA-PAC RECYCLING MACHINERY

HYDRA-PAC, A DIVISION OF TORQUE INDUSTRIES, SPECIALISES IN MANUFACTURING WASTE AND RECYCLING MACHINERY. HYDRA-PAC PROVIDES CLIENTS WITH A COMPLETE WASTE SOLUTION THAT IS SAFE, CLEAN AND AFFORDABLE.

HOW WE MANAGE WASTE REQUIRES A RETHINK. TALK TO US ABOUT HOW WE CAN HELP YOU TAKE STEPS TO REDUCE, REUSE, RECYCLE AND OPTIMISE YOUR WASTE MANAGEMENT APPROACH. YOU MIGHT EVEN SAVE SOME CASH!

FROM A SINGLE LOCATION TO MULTI-SITE OPERATIONS, HYDRA-PAC HAS A RECYCLING UNIT THAT WILL SUIT YOUR NEEDS. THE BRAND IS SUPPORTED BY A NATIONAL NETWORK OF SERVICE PROVIDERS ENSURING OPERATING UNITS ARE MAINTAINED IN PEAK CONDITION DELIVERING MANY YEARS OF TROUBLE FREE USAGE.

SPECIFICATIONS

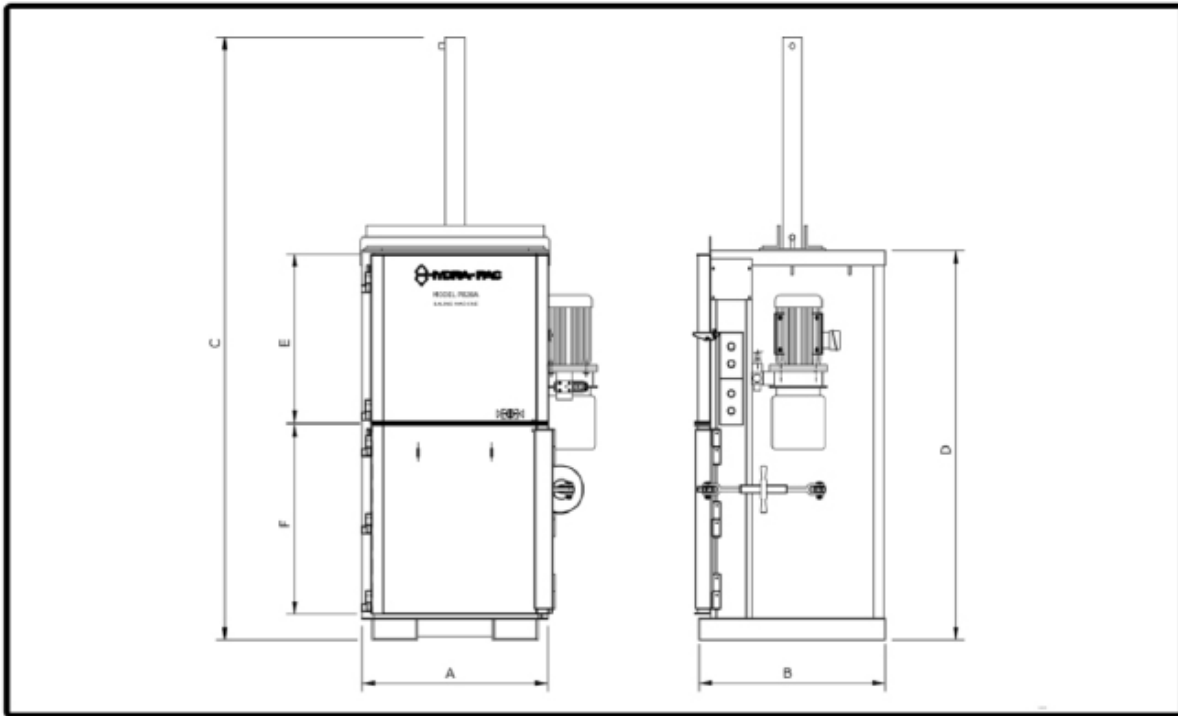

Model Specifications	A	B	C	D	E	F
BP28A	810	1060	2750	1802	735	925
PB40A	850	1375	2715	1792	735	925

Model		PB28A	PB40A
Expanded Bale Size	High (mm/in)	1000 / 39	1145 / 45
	Wide (mm/in)	710 / 28	1000 / 40
	Deep (mm/in)	710 / 28	750 / 29
Bale Weight	Cardboard (kg) (lbs)	90 - 110	130 - 160
		202 - 247	292 - 360
Loading Opening	(mm)	710W x 635H	1000W x 635H
	(in)	28W x 25H	40W x 25H
Time Cycle		14 Seconds	27 Seconds
Electric Motor	(kW)	3kW, 415 Volt 3 Phase, 10 Amp	3kW, 415 Volt 3 Phase, 10 Amp
Shipping Weight	Approx, (kg)	600	850

Performance rates, bale weights and bale densities are subject to moisture content, material pre-bale density, method of feeding and other variable's in baling.

Specifications subject to change without notice.
All Imperial weights based on 1 Ton = 2240lbs.



proudly manufactured by:

Visit our Website
www.torqind.com

Call Toll Free in Australia
(excluding South Australia)
1800 064 455



246 Grand Junction Road
Athol Park, SA 5012
Telephone: +618 8341 0177
Facsimile: +618 8341 1955
Email: sales@torqind.com

VERTICAL "PB" SERIES BALERS

PB48A & PB60A

The PB48A and PB60A are work horses for your large supermarket or warehouse situatuons that calls for baling higher volumes and larger sized cartons.

The twin side rams make this machine perfect for tight areas where low roof height are a problem.

The Pallet jack access holes suit most standard pallet jacks and allows for easy positioning and moving for cleaning.

Our door locking system ensures total control when opening the door. This maximises safety and useability for the operator.

Specifications

Bale Size	1220 W x 760 x 1015	1520 x 760 x 1015 H
Bale Weight	240 - 250 kg	325 - 375 kg
Machine Dimensions	2195 W x 887 x 2490	2602 x 887 x 2534H
Loading Opening	1220 x 625	1220 x 625
Machine Weight	1450kg	1850kg
Time Cycle	24 Seconds	34 Seconds
Electrical Motor	4 kW - 415 Volt	4 kW - 415 Volt
Model Number	PB48A	PB60A



SALES SERVICE SOLUTIONS

SALES

[HYDRAULICS](#)
[PNEUMATICS](#)
[AIR COMPRESSORS & GAS GENERATORS](#)
[FILTRATION PRODUCTS](#)
[HOSES & FITTINGS](#)
[VACUUM EQUIPMENT](#)
[MATERIAL HANDLING](#)



SERVICE

[SERVICE DIVISON](#)
[24/7 EMERGENCY BREAKDOWN SERVICE](#)
[REPAIR CENTRE](#)
[PROGRAM MAINTENANCE](#)



SOLUTIONS

HYDRA-PAC RECYCLING MACHINERY

HYDRA-PAC, A DIVISION OF TORQUE INDUSTRIES, SPECIALISES IN MANUFACTURING WASTE AND RECYCLING MACHINERY. HYDRA-PAC PROVIDES CLIENTS WITH A COMPLETE WASTE SOLUTION THAT IS SAFE, CLEAN AND AFFORDABLE.

HOW WE MANAGE WASTE REQUIRES A RETHINK. TALK TO US ABOUT HOW WE CAN HELP YOU TAKE STEPS TO REDUCE, REUSE, RECYCLE AND OPTIMISE YOUR WASTE MANAGEMENT APPROACH. YOU MIGHT EVEN SAVE SOME CASH!

FROM A SINGLE LOCATION TO MULTI-SITE OPERATIONS, HYDRA-PAC HAS A RECYCLING UNIT THAT WILL SUIT YOUR NEEDS. THE BRAND IS SUPPORTED BY A NATIONAL NETWORK OF SERVICE PROVIDERS ENSURING OPERATING UNITS ARE MAINTAINED IN PEAK CONDITION DELIVERING MANY YEARS OF TROUBLE FREE USAGE.

SPECIFICATIONS

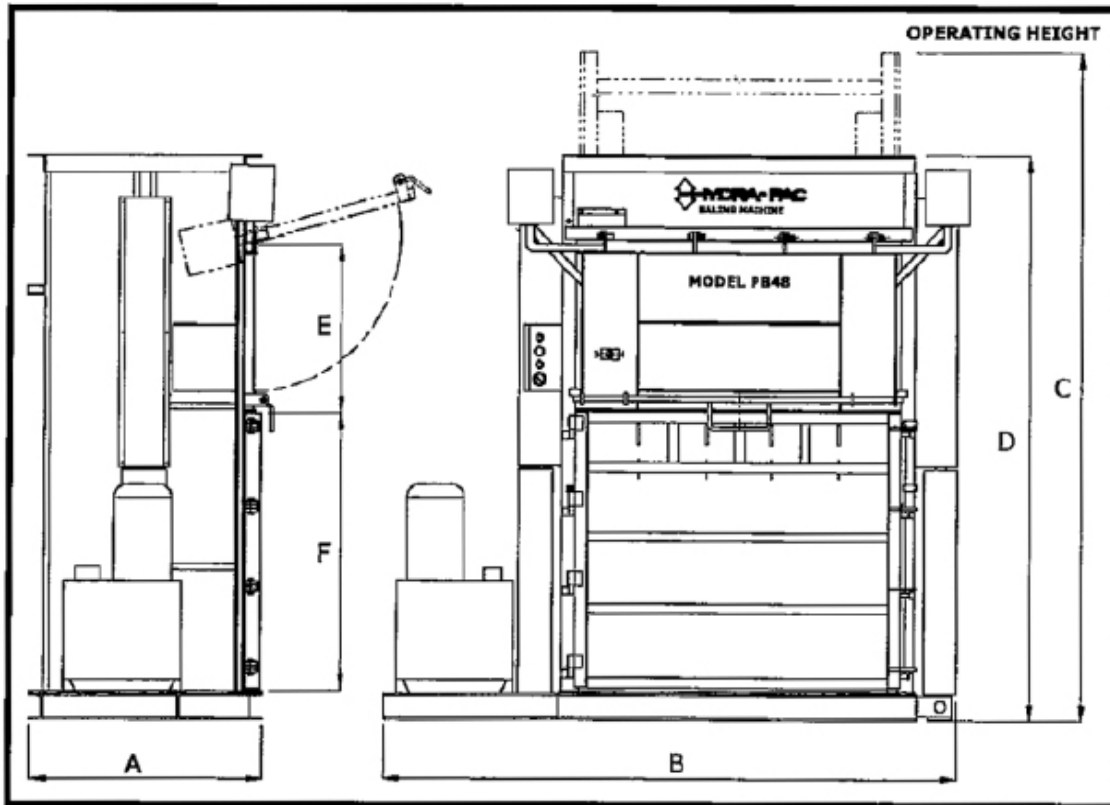

Model Specifications	A	B	C	D	E	F
PB48A	887	2195	2490	2105	685	1035
PB60A	887	2602	2534	2155	685	1035

Model		PB48A	PB60A
Expanded Bale Size	High (mm/in)	1015 / 40	1015 / 40
	Wide (mm/in)	1220 / 48	1520 / 60
	Deep (mm/in)	765 / 30	765 / 30
Bale Weight	Cardboard (kg) (lbs)	240 - 250	325 - 375
		540 - 562	730 - 843
Loading Opening	(mm)	1220W x 685H	1520W x 685H
	(in)	48W x 27H	60W x 27H
Time Cycle		24 Seconds	34 Seconds
Electric Motor	(kW)	4kW, 415 Volt 3 Phase, 20 Amp	3kW, 415 Volt 3 Phase, 20 Amp
Shipping Weight	Approx, (kg) (lbs)	1,450	1,850
		3,260	4,160

Performance rates, bale weights and bale densities are subject to moisture content, material pre-bale density, method of feeding and other variable's in baling.

Specifications subject to change without notice.



proudly manufactured by:

Visit our Website
www.torqind.com

Call Toll Free in Australia
(excluding South Australia)
1800 064 455

TORQUE
INDUSTRIES

246 Grand Junction Road
Athol Park, SA 5012
Telephone: +618 8341 0177
Facsimile: +618 8341 1955
Email: sales@torqind.com