

SPECIFICATIONS

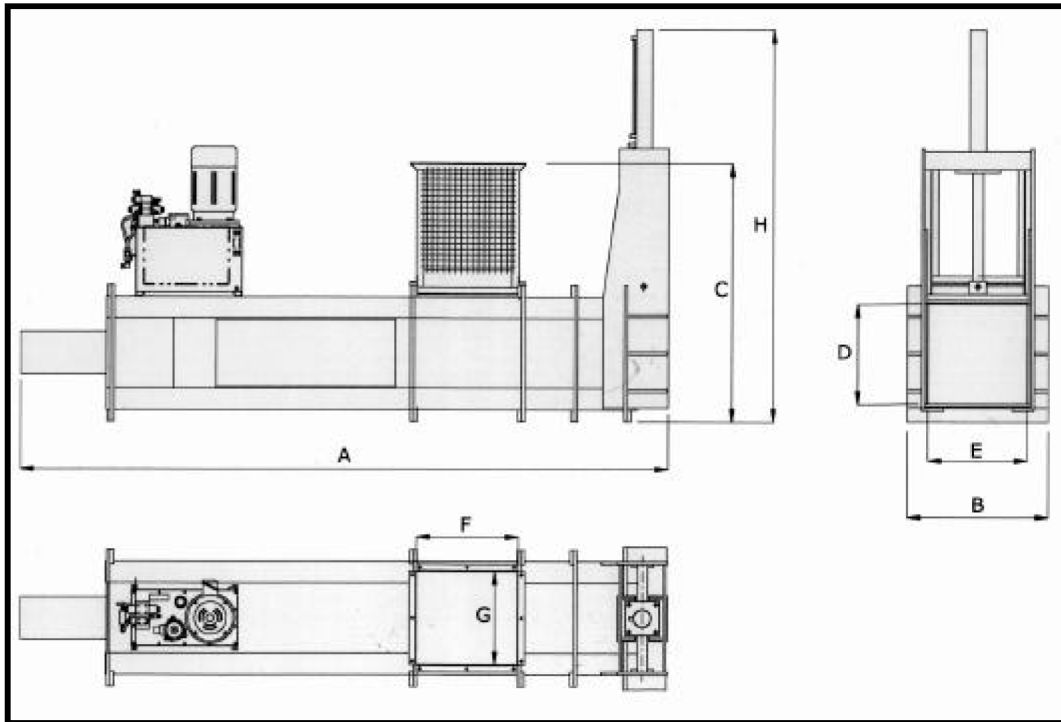

MODEL SPECS	A	B	C	D	E	F	G	H
HCC 4030-35C (mm)	3545	620	1486	300	400	724	400	1480
(in)	140	24	59	12	16	29	16	58
HCC 5757-60C (mm)	5300	810	1645	570	570	700	570	2295
(in)	208	31	64	22	22	27	22	90
HCC 7070-80C (mm)	4551	990	1800	700	700	700	700	2730
(in)	171	39	70	27	27	27	27	107

MODEL	HCC 4030-35C	HCC 5757-60C	HCC7070-80C
Expanded Bale Size			
High (mm / in)	300 / 12	570 / 22	700 / 27
Wide (mm / in)	400 / 15	570 / 22	700 / 27
Long (mm / in)	150 - 250 / 6 - 10	1145 / 45	700 / 27
Bale Weight			
Al / Steel (kg)	7 - 9 / 18 - 23	170 - 190 / 442 - 494	190 - 220 / 494 - 572
(lbs)	15 - 20 / 40 - 51	382 - 495 / 994 - 1111	427 - 495 / 1111 - 1287
Operating Pressure	35 (Tons)	60	80
Machine Capacity / Hr.			
Al / Steel (kg)	210-230 / 546-620	380 - 425 / 988 - 1105	450 - 560 / 1170 - 1456
(lbs)	472-517 / 1228-1395	855 - 900 / 2220 - 2340	1012 - 1260 / 2630 - 3276
Ram Face Pressure	423 (PSI)	268	237
Electric Motor	22 (kW)	22	22
Main Cylinder			
mm	165	228	254
(in)	6.5	9	10
Shipping Weight	2200 (Approx. kg)	5250	5500

Performance rates, bale weights and bale densities are subject to moisture content, material pre-bale density, method of feeding and other variables in baling.



proudly manufactured by:



246 Grand Junction Road
 Athol Park S.A. 5012
Ph: +61 8 8341 0177
 Fax: +61 8 8341 1955

Visit our website
www.torqind.com

email: sales@torqind.com

Call Toll Free in Australia
 (excluding South Australia)

1800 064 455